



MODEL 545SD 30/15 TON AXLE JACK

PART			KIT INCLUDES	
ORDER NUMBER	KIT DESCRIPTION	REF. #	DESCRIPTION	QTY
545SD01	SWITCH COMPLETE	1	SWITCH COMPLETE	1
545SD02	AIR HOSE	2	AIR HOSE	1
545SD03	WHEEL SET	3	WHEEL SET	1
545SD04	HANDLE SET	4	HANDLE SET	1
545SD05	TIE IN	5	TIE IN	1
545SD06	AIR HOSE KIT	6	AIR HOSE KIT	1
545SD07	PUMP	7	PUMP	1
545SD08	CHECK VALVE	8	CHECK VALVE	1
545SD12	CYLINDER COMPLETE	12	CYLINDER COMPLETE	1
545SD14	TUBE	14	TUBE	1
545SD44	SPONGE	44	SPONGE	1
545SD47	EXHAUST HOOD	47	EXHAUST HOOD	1
545SD50	PROTECTION HOOD	50	PROTECTION HOOD	1
545SDRK	REPAIR KIT		REPAIR KIT	1

*ONLY PARTS WITH PART ORDER NUMBER ARE AVAILABLE FOR SALE
DO NOT COPY OR DISTRIBUTE THIS MATERIAL WITH OUT PERMISSION OF AFF, INC.

Pump

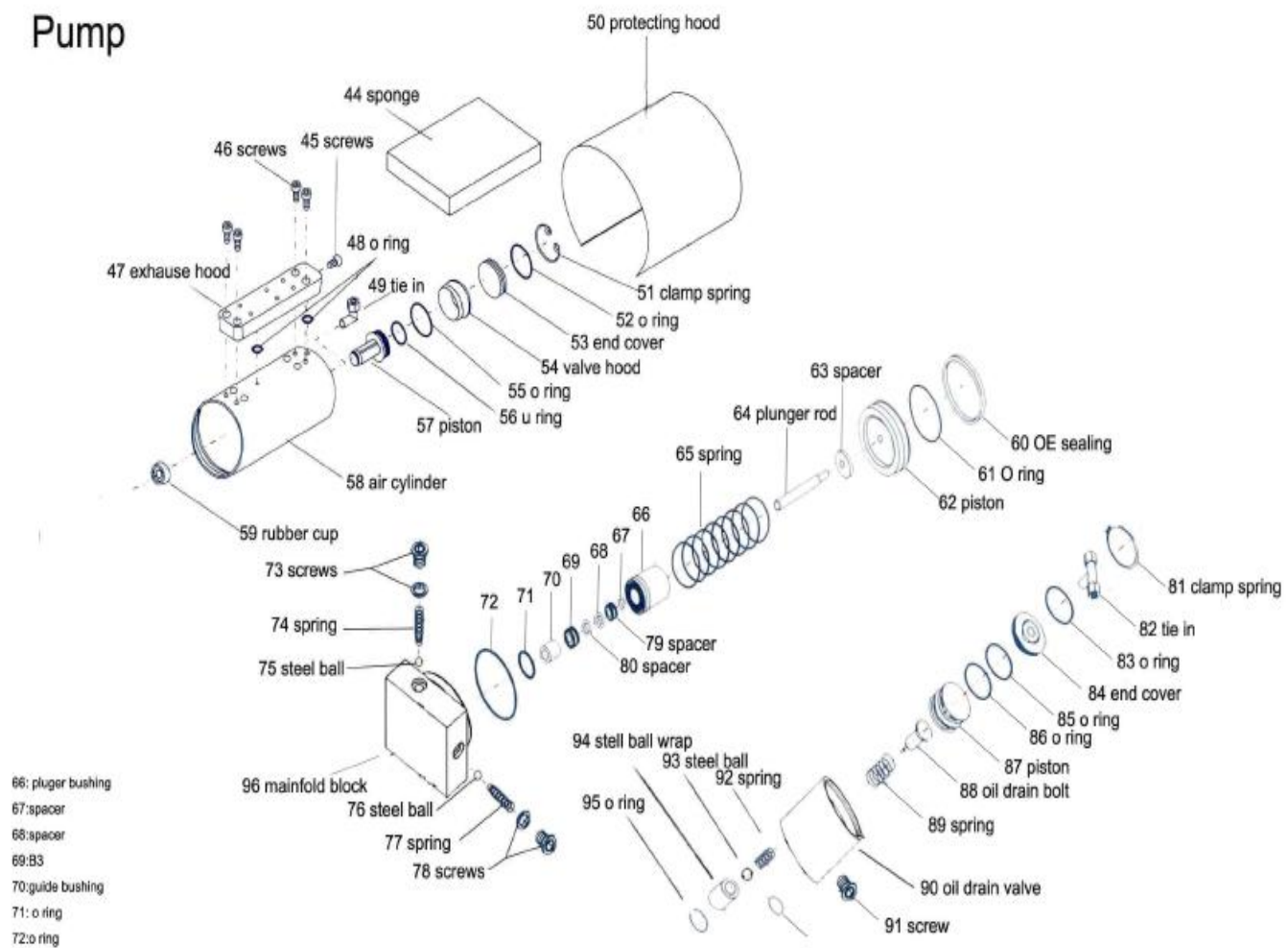

*ONLY PARTS WITH PART ORDER NUMBER ARE AVAILABLE FOR SALE
DO NOT COPY OR DISTRIBUTE THIS MATERIAL WITH OUT PERMISSION OF AFF, INC.

CYLINDER

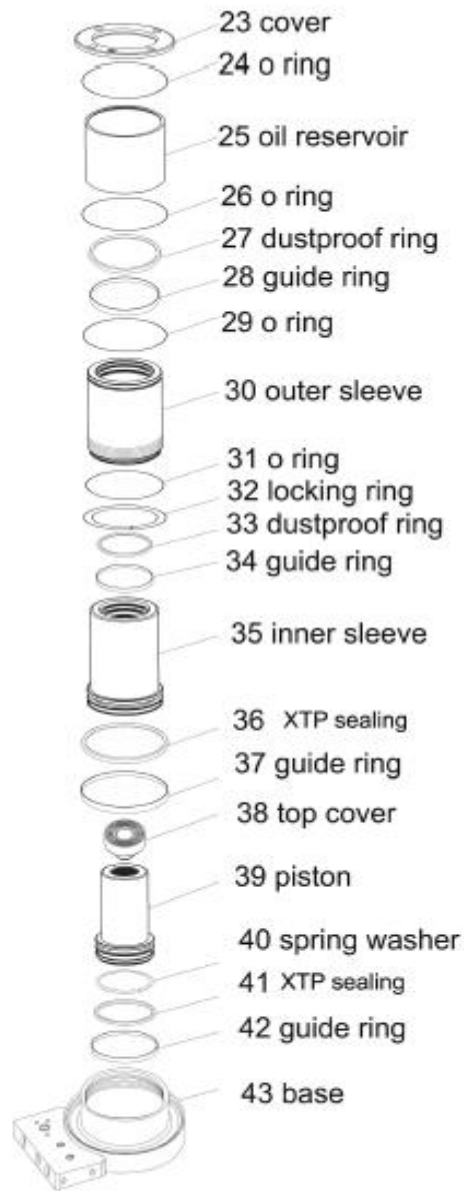

*ONLY PARTS WITH PART ORDER NUMBER ARE AVAILABLE FOR SALE
DO NOT COPY OR DISTRIBUTE THIS MATERIAL WITH OUT PERMISSION OF AFF, INC.

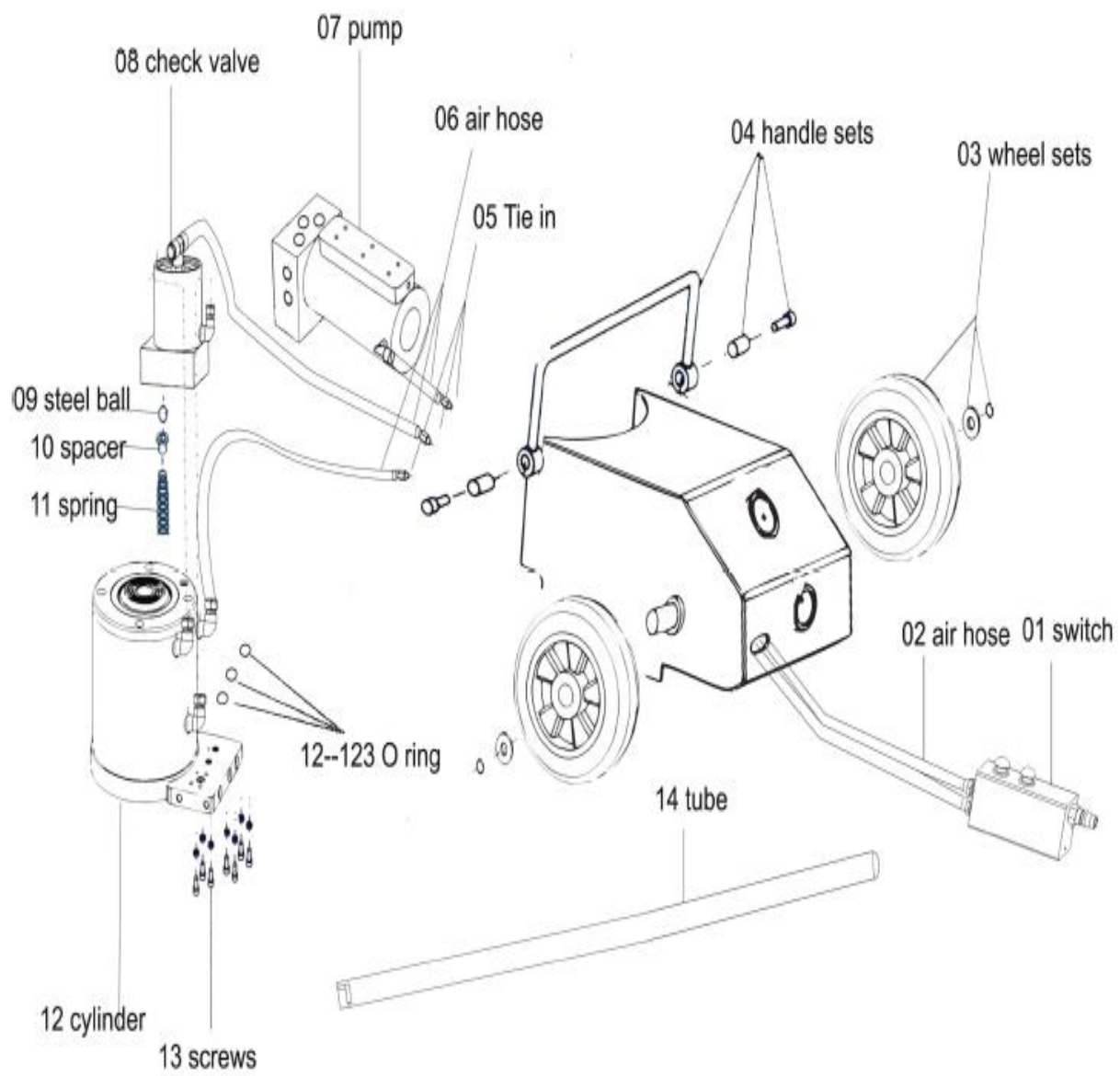

*ONLY PARTS WITH PART ORDER NUMBER ARE AVAILABLE FOR SALE
DO NOT COPY OR DISTRIBUTE THIS MATERIAL WITH OUT PERMISSION OF AFF, INC.