

**MOTORCYCLE WHEEL BALANCER**

**CEMB** USA

**K22**

**DESIGNED FOR  
MOTORCYCLES  
ONLY**



**Digital Wheel Balancer for  
motorcycles and scooters**

Visit our website to see our complete  
range of wheel balancers  
and other products



**BOB**

Balances Wheels  
on their own Wheel  
Bearings

**MHB**

Manual hand  
Brake

**2D**

Automatic Distance  
and Diameter



**CEMB**

Established 1946  
USA since 1969

**WWW.CEMB-USA.COM**

# MOTORCYCLE WHEEL BALANCER



## CEMB K22 BALANCING MACHINES

**Digital wheel balancer for motorcycles and scooters**

### FEATURES

- The shaft of the balancing machine is fixed so that the wheel rotates freely on its own bearings. This simulates exactly the assembly of the wheel on the motorbike and eliminates all the assembly inaccuracies which are inevitable with traditional balancing machines for car wheels where the adapter is put in rotation with the wheel
- Static and Dynamic balance
- Automatic distance and diameter entry (2D)
- Balances scooter wheels (hand spin)
- Balances bearing type and single sided swing arm (with optional AGF adaptor set)

### STANDARD ACCESSORIES

- 15mm threaded shaft
- 2 cones 15mm - 25mm
- Shaft nut and washer

### OPTIONAL ACCESSORIES

- AGF kit for single arm type (flange) wheels
- Harley Davidson shaft extension
- Kawasaki Suzuki shaft extension
- Shaft extensions

### TECHNICAL SPECIFICATIONS

- Power supply 110VAC
- Balancing speed < 80 rpm
- Balancing accuracy < 1 g
- Rim diameter 10" - 30"
- Rim width 1.5" - 20"
- Max wheel weight 66 lbs (30 Kg)
- Average cycle time 6 - 8 seconds
- Operating temperature 32° -113°F (0° - 45°C)
- Shipping dimensions (L 58" x W 43" x H 59")
- Gross shipping weight 240 lbs



*Manufacturer reserves the right to make any and all alterations it may consider suitable without notice*

### BALANCER FOOT PRINT

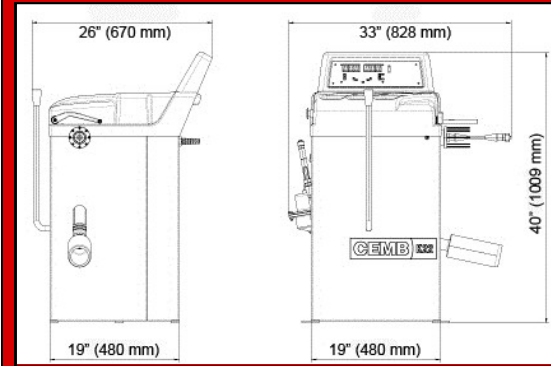

### CEMB TECHNOLOGIES



All parts used to manufacture our machines are of the highest quality available. Only in this way is it possible to maintain constant accurate balancing over time.



Sales and technical support network in over 85 countries.

A team of specialists at the customer's service.

## CEMB <sup>USA</sup>

**BL Systems, Inc.**

2873 Ramsey Road • Gainesville, GA 30501  
Toll free 877-259-4335 • Office 678-717-1050  
Fax 678-717-1056 • sales@cemb-usa.com

**DISTRIBUTED BY**

**Related Models C29MC • K8MC**

CATK22-1

**WWW.CEMB-USA.COM**