

ASSEMBLY INSTRUCTIONS:

1. CLEAN RUNWAYS OF EXISTING DIRT & DEBRIS
2. LAYOUT DB-6000 KIT ONTO RUNWAYS & MARK MOUNTING HOLES
3. REMOVE DB-6000 KIT AND TOUCH-UP HOLES & SCRATCHES WITH PAINT
4. ALLOW PAINT TO DRY (SEE MANUFACTURERS RECOMMENDED INSTRUCTIONS)
5. BEGINNING AT THE END OF THE RUNWAY OPPOSITE THE RAMP, BEGIN INSTALLING DB-6000 COMPONENTS
6. AFTER ALL PARTS HAVE BEEN SECURED, RE-TIGHTEN ALL HARDWARE

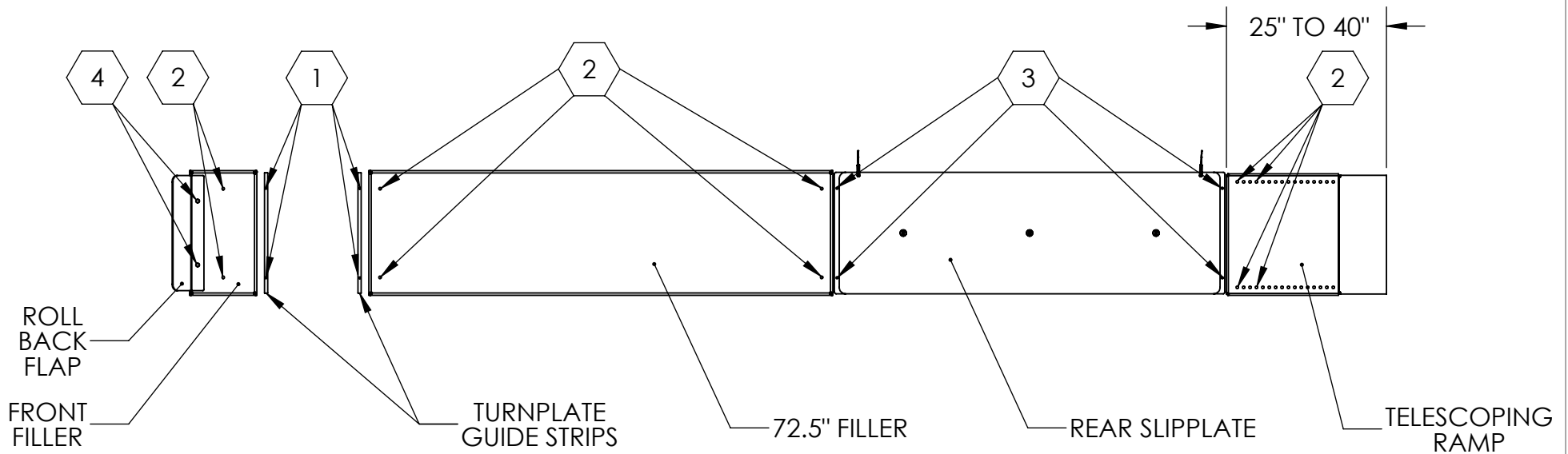

HARDWARE ARRANGEMENT

1	1/4" HARDWARE	1/4-20 X 1 HEX HEAD CAP SCREW	1/4" USS FLAT WASHER	1/4-20 NYLON INSERT LOCK NUT	
2	3/8" HARDWARE	3/8-16 X 2-1/2 HEX HEAD CAP SCREW	3/8" USS FLAT WASHER	3/8-16 NYLON INSERT LOCK NUT	
3	5/16" HARDWARE	5/16-18 X 1-1/2 HEX HEAD CAP SCREW	5/16" USS FLAT WASHER	5/16-18 NYLON INSERT LOCK NUT	
4	1/2" HARDWARE	1/2-13 X 1-1/2 HEX HEAD CAP SCREW	1/2" USS FLAT WASHER	1/2-13 NYLON INSERT LOCK NUT	1/2" SPLIT LOCK WASHER



DB-6000

DB-6000 ASSEMBLY INSTRUCTIONS

PROPRIETARY AND CONFIDENTIAL

THE INFORMATION CONTAINED IN THIS DRAWING IS THE SOLE PROPERTY OF QSP. ANY REPRODUCTION IN PART OR AS A WHOLE WITHOUT THE WRITTEN PERMISSION OF QSP IS PROHIBITED.

SCALE: 1:24