



11515 Adie Rd. Maryland Heights, MO 63043

Phone (888) 473-5378  
Local Phone (314) 699-9613  
Fax: (314) 699-9617  
Website: [www.qsponline.com](http://www.qsponline.com)

---

## LM-350 Warranty

The LM-350 has been thoroughly tested and is guaranteed for a period of 12 months from the date of delivery. Under the terms of this guarantee all components which are proven defective within the warranty period will be repaired or replaced free of charge. Our technical assistance service is the sole authority in determining whether or not defects come under the coverage of the guarantee. The guarantee excludes all responsibility on the part of the Quality Stainless Products for direct or indirect loss or damage to persons or things deriving from incorrect operation or servicing of the product. The guarantee is limited to defects in materials, workmanship and assembly, and excludes all components subject to normal wear. Furthermore, the guarantee excludes return shipping of defective part to QSP. We will however ship the replacement part by standard ground service at no charge.

### Parts Department 888-473-5378

TYPE: Tire and Wheel lift

MODEL: LM-350

---

## OPERATION INSTRUCTIONS

### Removing the Tire and Wheel Assembly from a vehicle using The LM-350

1. Attach air to LM-350
2. Position LM-350 under tire and wheel on the vehicle and raise roller carriage by operating the raise/lower control. (Valve is variable speed. The more you move the toggle control in the upward or downward direction the faster the carriage will move)
3. Once the rollers have made contact with the bottom of the tire, slowly release the toggle valve.
4. Pull the top of the tire toward you and disengage wheel from the vehicle.
5. With the tire on the rollers back the lift away from the vehicle and lower.
6. Remove the tire and wheel assembly from the LM-350

### Installing the Tire and Wheel Assembly on a vehicle using the LM-350

1. Position the tire and wheel assembly on the LM-350 rollers
2. Raise the tire to close to spindle height.
3. Rotate the tire and wheel to align lug studs to the wheel.
4. Slowly raise or lower to exact position and push the top of the tire and wheel assembly forward to engage the stud and lug nut holes.
5. Install lug nuts and lower tire and wheel lift.

# LIFTING CAPACITY: 350LBS

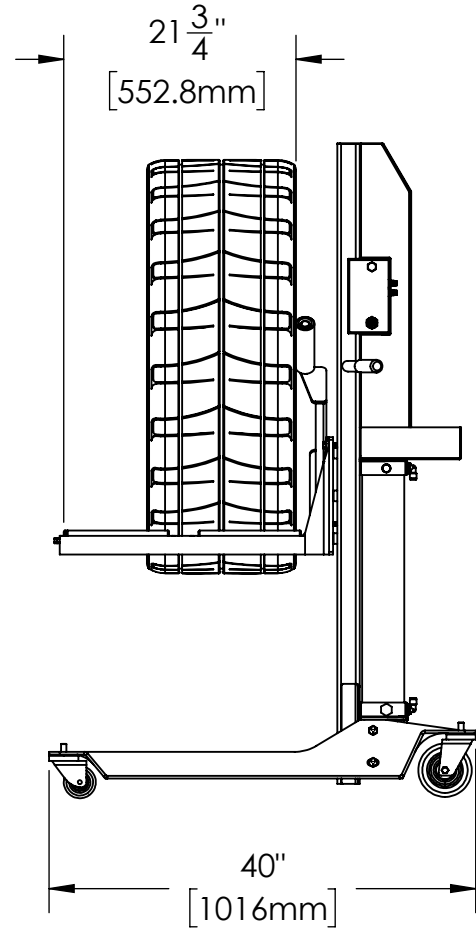
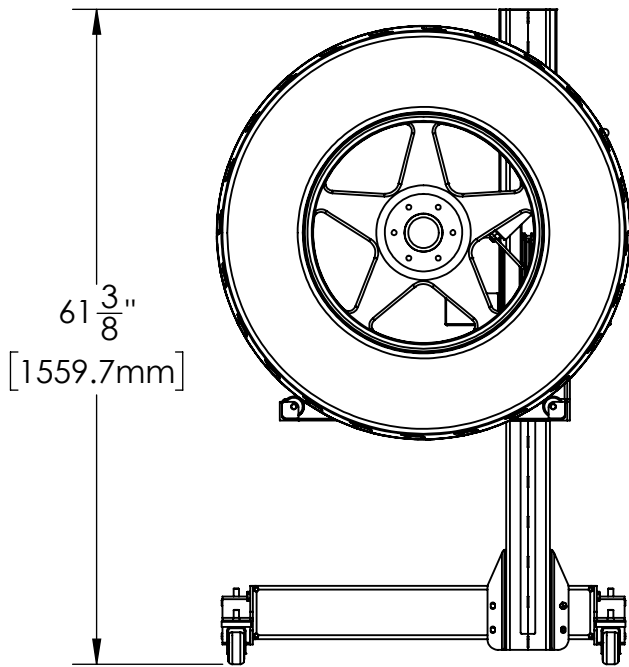
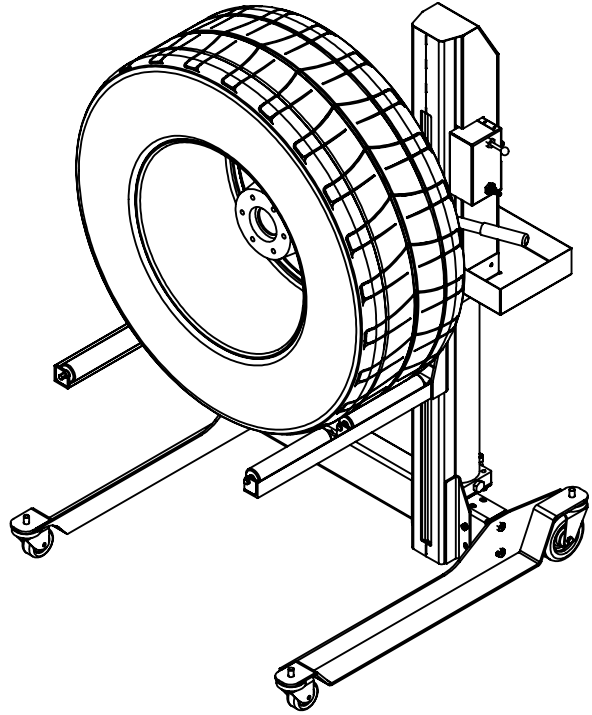
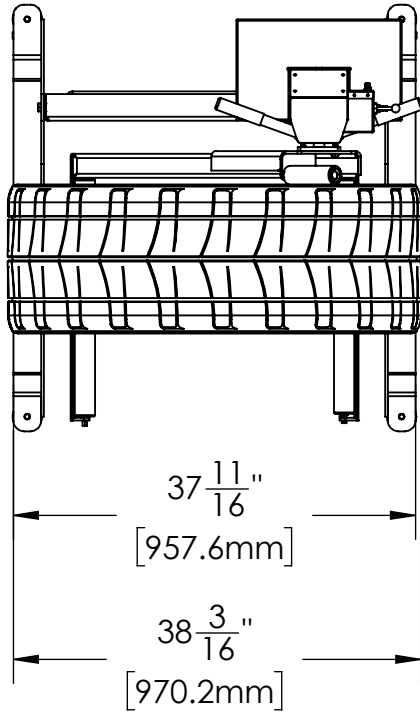

## LM-350 INSTALLATION & ASSEMBLY INSTRUCTION

PROPRIETARY AND CONFIDENTIAL  
THE INFORMATION CONTAINED IN THIS DRAWING IS THE SOLE PROPERTY OF QSP. ANY REPRODUCTION IN PART OR AS A WHOLE WITHOUT THE WRITTEN PERMISSION OF QSP IS PROHIBITED.

ITEM NO.	PART NUMBER	DESCRIPTION	
1	LM-200-172	CONTROL BOX COVER	1
2	LM-200-415	ROLLER SUPPORT	1
3	LM-200-901	AIR VALVE	1
4	LM-200-930	CASTER 5" DIA WHEEL	2
5	LM-200-931	CASTER 3" DIA WHEEL	2
6	LM-200-R-152	ROLLER	1
7	LM-350-10	LM-350 DECAL KIT	1
8	LM-350-100	HD Cylinder 100 B- 500 S	1
9	LM-350-112	COLUMN WELDED ASSY	1
10	LM-350-117	TROLLEY WELDMENT	1
11	LM-350-119	SPACER	3
12	LM-350-120	SUPPORT PLATE	1
13	LM-350-122	FORK WELDMENT	1
14	LM-350-131	ROLLER	4
15	LM-350-136	PULLEY WELDMENT LM-350	1
16	LM-350-137	ROLLER	2
17	LM-350-140	ROLLER PIN	1
18	LM-350-141	CABLE RETAINER	2
19	LM-350-142	PULLEY PIN	2
20	LM-350-144	COVER LH	1
21	LM-350-145	COVER LH	1
22	LM-350-146	COVER REAR	1
23	LM-350-147	TOOL TRAY	1
24	LM-350-148	ROLLER-TROLLEY	6
25	LM-350-149	CHANNEL ASSY	1
26	LM-350-714	CASTER SUPPORT RH	1
27	LM-350-715	CASTER SUPPORT LH	1
28	LM-500-301	PULLEY 5" OD X 1/2" W	1
29	LM-500-705	LM-500 CABLE ASSEMBLY	1
30	1030	QUICK DISCONNECT 1/4 NPT	1
31	108-60	CHECK VALVE 1/4 NPT	1
32	1345	1/4 NPT-3/4-16 THD	1
33	1347	AIR LINE TEE 1/4 NPT	1
34	137-71	YELLOW COIL HOSE 4 1/2 COIL	1
35	8000-8	GRIP	2
36	F-1/2NPT X 3/8T L	1/2 NPT X 3/8 TUBE ELBOW	2
37	F-1/4 X 1/4NPT L	.25 TUBE X .25NPT ELBOW	1
38	F-1/4NPTX3/8T FCL	FLOW CONTROL ELL 3/8 NPT	2
39	H-LM-350 HW	LM-350 HARDWARE KIT	1
40	T-1/4 PU TUBE-FLEX	1/4 BLACK POLYURETHANE AIR LINE	0.75
41	T-3/8 PU BLACK TUBE	3/8 PLACK POLYURETHANE TUBE	6



## LM-350 INSTALLATION & ASSEMBLY INSTRUCTION

PROPRIETARY AND CONFIDENTIAL  
 THE INFORMATION CONTAINED IN THIS DRAWING IS THE SOLE PROPERTY OF QSP. ANY REPRODUCTION IN PART OR AS A WHOLE WITHOUT THE WRITTEN PERMISSION OF QSP IS PROHIBITED.

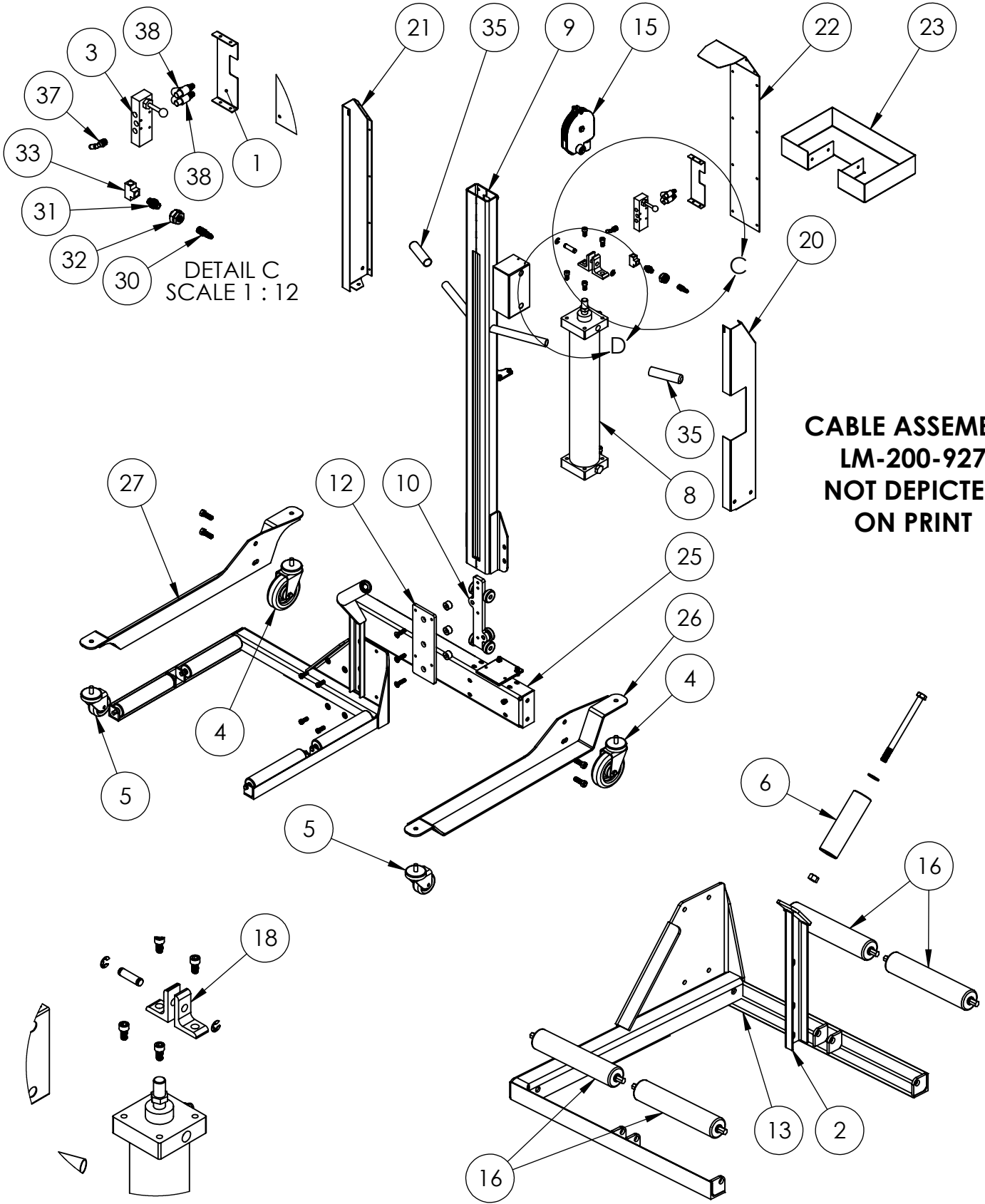

**CABLE ASSEMBLY  
LM-200-927  
NOT DEPICTED  
ON PRINT**

DETAIL D  
SCALE 1 : 9



**LM-350 INSTALLATION & ASSEMBLY INSTRUCTION**

**PROPRIETARY AND CONFIDENTIAL**  
THE INFORMATION CONTAINED IN THIS DRAWING IS THE SOLE PROPERTY OF QSP. ANY REPRODUCTION IN PART OR AS A WHOLE WITHOUT THE WRITTEN PERMISSION OF QSP IS PROHIBITED.

## STEP #1 CASTER INSTALLATION.

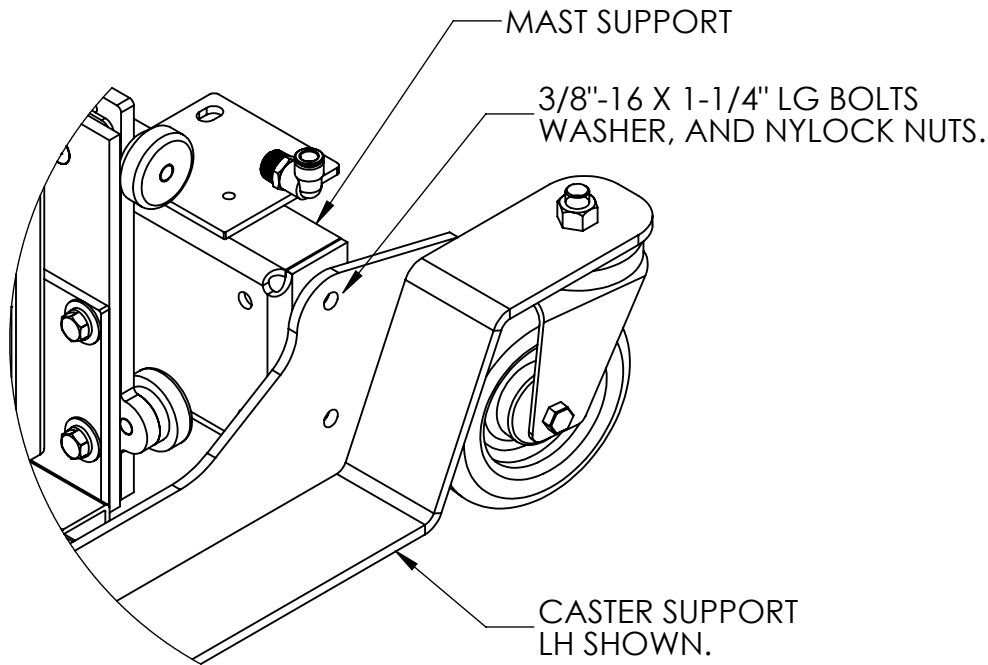

1. ATTACH CASTER SUPPORTS RH & LH TO MAST SUPPORT USING HARDWARE NOTED.

## STEP #2 MAST INSTALLATION

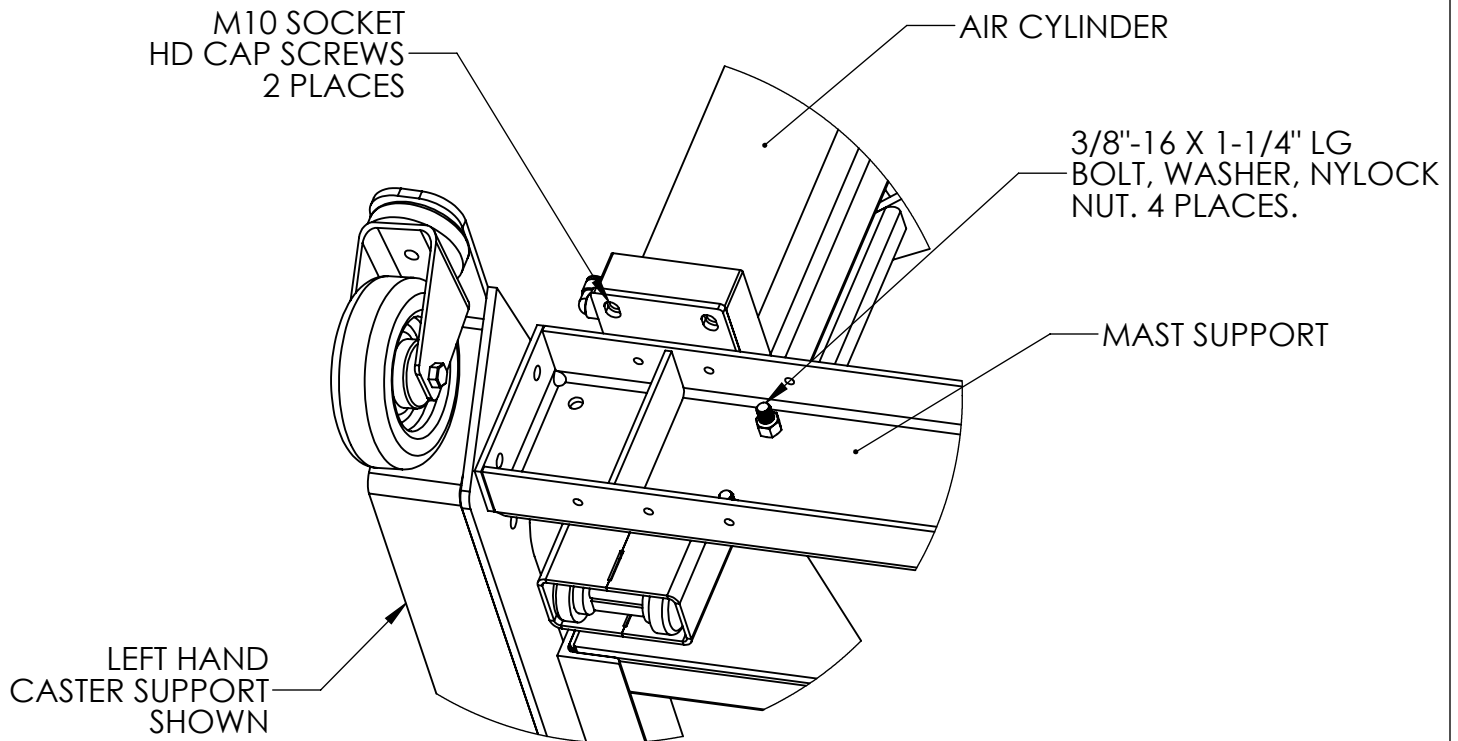

1. ATTACH THE MAST TO THE MAST SUPPORT USING HARDWARE NOTED.

### STEP #3 FORK INSTALLATION.

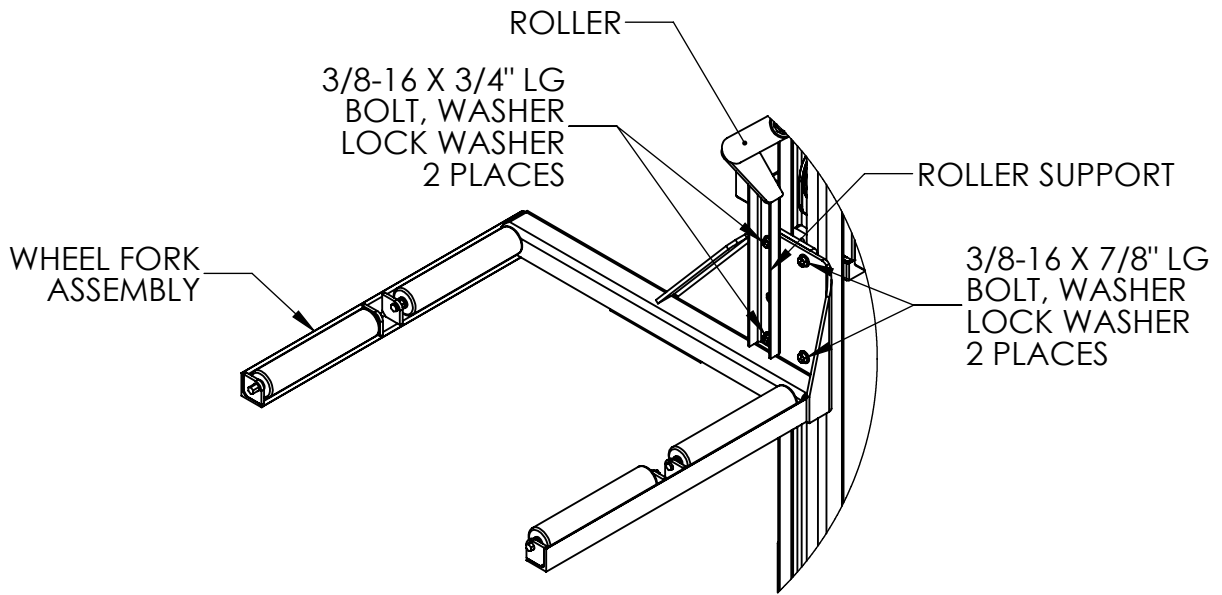

ATTACH WHEEL FORK ASSEMBLY WITH HARDWARE NOTED. IMPROPER LOCATION OF HARDWARE CAN CAUSE INTERFERENCE OF BOLT WITH MAST.

### STEP #4 TOOL TRAY INSTALLATION.

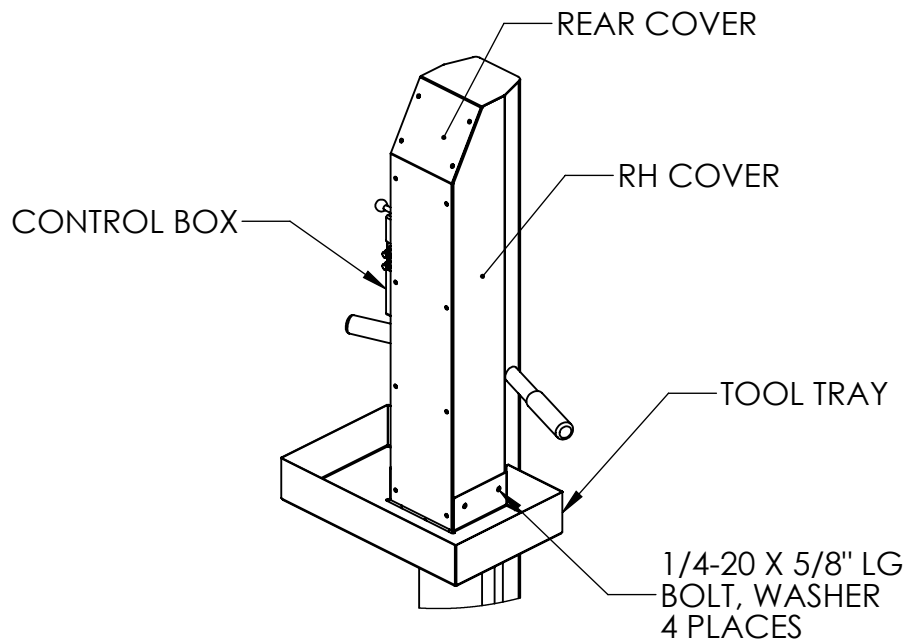

## STEP #5 AIR LINE CONNECTION

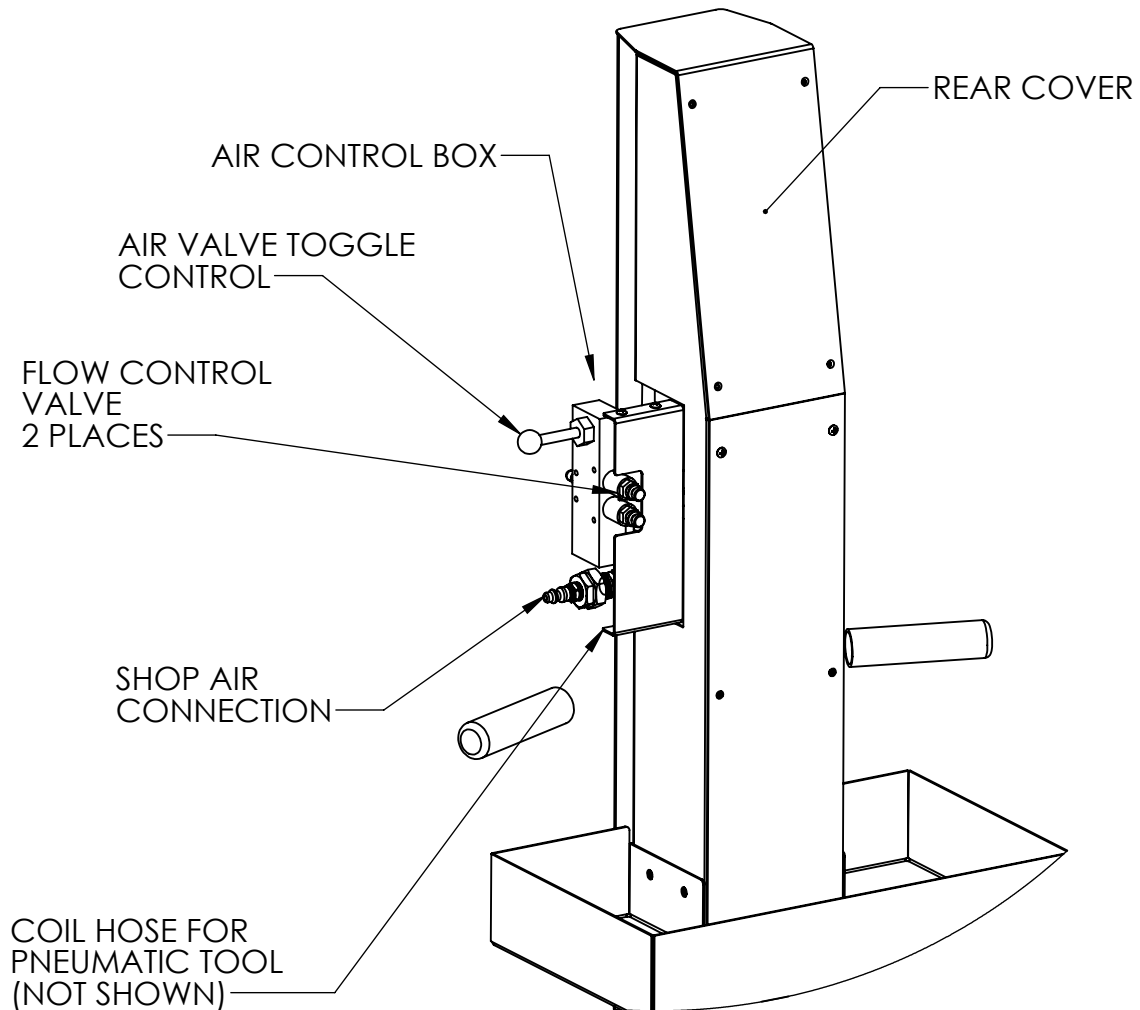

**NOTE:**  
THE FLOW CONTROL VALVES GOVERN THE RATE AT WHICH THE WHEEL FORK RAISES AND LOWERS. THESE CONTROLS ARE PRESET AT THE FACTORY, BUT CAN BE ADJUSTED BY THE END USER IF THE DESIRED SPEED NEEDS TO BE INCREASED OR DECREASED.

### SUGGESTED MAINTENANCE:

1. **THE LM-350 LIFT OPERATES BEST WITH SHOP AIR THAT IS CLEAN AND DRY.**
2. **PERIODICALLY CHECK THE TIGHTNESS OF ALL FASTENERS.**
3. **PERIODICALLY CHECK THE CONDITION OF LIFTING CABLE. IF ANY FRAYED STRANDS ARE NOTICED REPLACE CABLE.**