

**HARDWARE KIT:**

- (7) 1/4-20 X 1" HHCS Z
- (7) 1/4-20 NYLOCK NUT Z
- (14) 1/4 FLAT WASHER Z
- (14) 3/8-16 X 2" LG HHCS Z
- (14) 3/8-16 NYLOCK NUT Z
- (28) FLAT WASHER Z

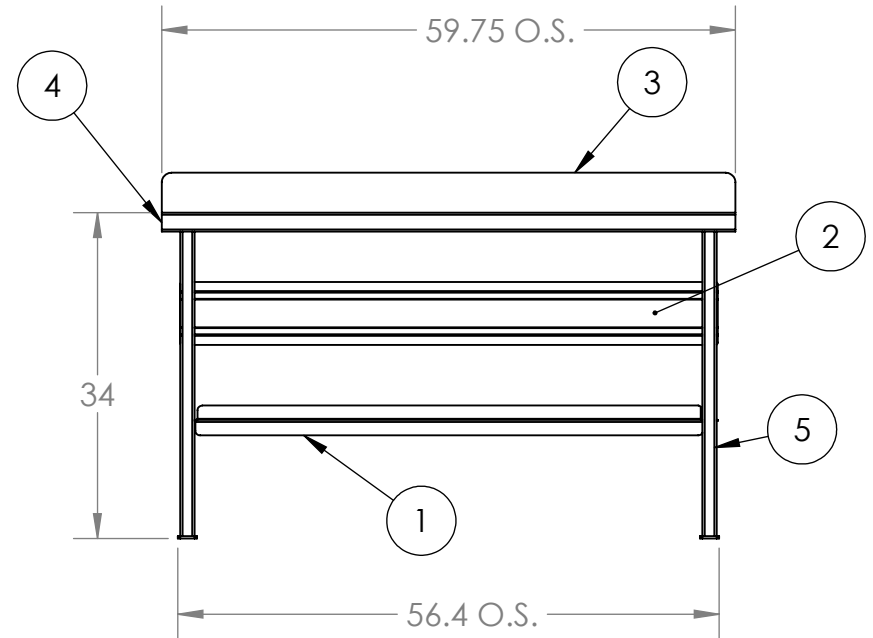
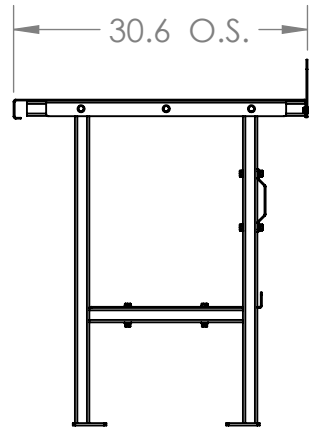
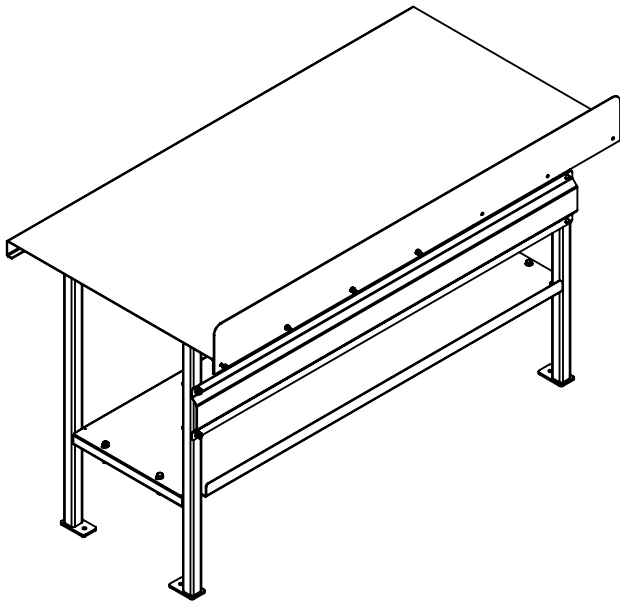

| ITEM NO. | PART NUMBER | QTY. |
|----------|-------------|------|
| 1        | WB-100-50   | 1    |
| 2        | WB-100-30   | 1    |
| 3        | WB-100-40   | 1    |
| 4        | WB-100-20   | 1    |
| 5        | WB-100-10   | 2    |

| Date     | Change                 | Rev # |
|----------|------------------------|-------|
| 10/22/15 | FEET CHANGED - CR10006 | A     |

UNLESS OTHERWISE SPECIFIED:  
 DIMENSIONS ARE IN INCHES  
 TOLERANCES:  
 FRACTIONAL ±  
 ANGULAR: MACH ± BEND ±  
 TWO PLACE DECIMAL ±  
 THREE PLACE DECIMAL ±

MATERIAL

FINISH  
 Debur & Break  
 Sharp Edges

DO NOT SCALE DRAWING



TITLE:

**WB-100**

|                  |                           |                 |
|------------------|---------------------------|-----------------|
| SIZE<br><b>A</b> | DWG. NO.<br><b>WB-100</b> | REV<br><b>A</b> |
|------------------|---------------------------|-----------------|

SCALE: 1:50

5

4

3

2

1